

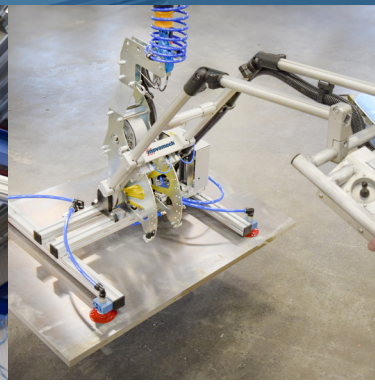

PRODUCTS AND SYSTEM SOLUTIONS

ERGONOMIC MATERIAL HANDLING

MECHRAIL™ | MECHCRANE™ | MOBIARM™ | MECHLINE PRO CRANE™
EASYCRANE™ | MOBICHAIN™
MECHLIFT PRO™ | MECHSTACK PRO™ | MECHSPACE PRO™ | MECHLINE PRO™
MECHCHAIN PRO™ | MECHSTICK PRO™ | VACUHAND™ | EASYHAND™



The right material handling solution lifts your work environment

Movomech's ergonomic material handling solutions contribute to healthier workplaces in industrial environments. By preventing musculoskeletal disorders, the chances for employees to thrive and for an efficient production increase.

Productivity, ergonomics and safety

With solid industry experience and cutting-edge knowledge in lifting technology and production ergonomics, we continuously develop our products for safe, sustainable, and efficient material handling.



Ergonomics is economical

Several international studies show that investing in ergonomic lifting equipment results in a more efficient production process, fewer work injuries, improved quality, and happier staff.



MOVOMECH AB

Movomech AB develops and manufactures a wide range of lifting products – from a first-class crane system in aluminium to complete material handling solutions with advanced lifting manipulators and tailor-made gripping tools.

The Movomech companies' headquarters and manufacturing facilities are situated in Kristianstad in southern Sweden, with global representation through sales offices and distributors worldwide.

Movomech AB is certified according to ISO 9001 and ISO 14001. Minimal environmental impact is a key part of all manufacturing and forms part of the strategic work.

ERGONOMICS

An essential factor within lifting technology and material handling

Ergonomics means the doctrine of adapting work and work environments to people's needs and conditions.

In practice, ergonomics often deals with how the workplace and work environment should be adapted not to cause unnecessary strain injuries, for example when it comes to work posture, work height and lifting technique.

Repeated lifting does not need to involve heavy weights to be both dangerous and costly. Even light lifting of 5-10 kg can cause strain injuries.

With products and solutions that help towards smarter and ergonomically correct lifting, occupational injuries with long rehabilitation periods and costly sick leave can be avoided.



Heavy lifting

Heavy lifting or heavy handling

Insufficient recuperation

Lack of physical recuperation



Lots of sick leave due to incorrect lifting

Half of occupational health problems in the manufacturing industry can be traced back to musculoskeletal disorders and many companies state that they have had staff on sick leave as a direct result of incorrect lifting.



Lack of variation

Same or similar movement at a fast tempo

Monotonous movements

Monotonous and repetitive movements



Risk factors

When assessing ergonomics for the prevention of musculoskeletal disorders in an activity, it is a question of identifying both sources of risk and early signs of inconvenience.

A few of the most common risk factors for musculoskeletal problems due to poor ergonomics are illustrated here in the opposite column.

On the Swedish Work Environment Authority's website, there is information and checklists for assessment of workplaces with regard to the lifting and moving of loads.

Read more at: www.av.se



Poor work posture

Badly bent or twisted work posture

Static work

Static muscular effort - e.g. with arms over shoulder height



...IS ECONOMICAL

” In the same way that the ergonomic problem means financial losses, great ergonomic work conditions can be reckoned in terms of profit and savings ”

Anki Falck, ergonom, Volvo Cars ¹



Reduce costs - increase quality

For assembly work in the automotive industry, ergonomic can cost on average, at a single workstation, just over MSEK 1 per year in direct costs for sick leave, staff turnover and rehabilitation.

At the same time, indirect costs for ergonomic problems can be twice as high, due to poor quality work, delivery delays and the need for increased staffing.

In the same way that bad ergonomics means financial losses, good ergonomic work conditions can be reckoned in terms of profit and savings due to simpler staff recruitment, better product quality and increased productivity.

¹ Source: Arbetsliv Magazine: "Bra ergonomi lönsamt" (Good ergonomics pays), H. Thornblad, dec 18. 2009

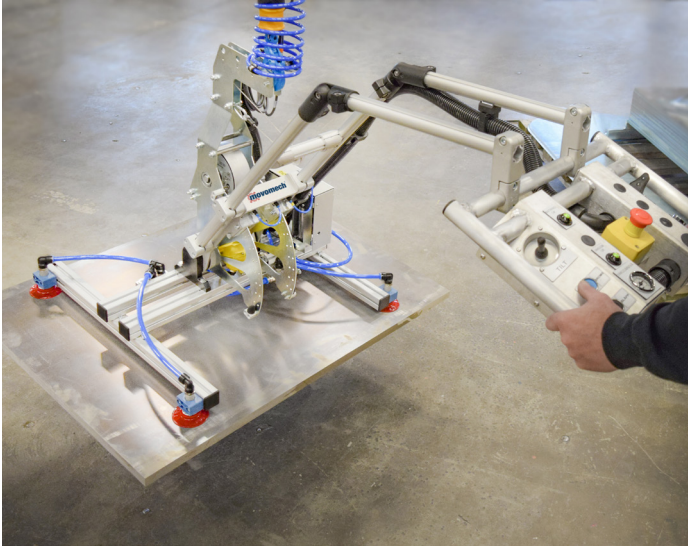

A unique product range

Since the outset, Movomech AB, has focused on supplying customized ergonomic handling solutions and have thus increased customers profitability by,

- more efficient production process
- fewer occupational injuries
- improved quality
- happier staff

”

Movomech offers an outstanding selection of ergonomic lifting and material handling equipment, with a scope unique for its kind.

”

100% Customer focus

Movomech’s main focus is to put customer needs first when designing a handling solution.

Thanks to a combination of...

- a comprehensive product range
- employee specialist skills
- the products suitability for customization

... unique opportunities are created to optimize the customer’s business!



OUR STANDARD IS SPECIAL

The optimization process affords the right solution

We go through the optimization process¹ with the customer step by step to find the best solution to the customers handling problem

Identification of customer needs

1

- What is going to be lifted?
- How often is it handled?
- What weights are involved?
- What is the handling area like?
- What are the handling risks?

Requirements & Guidelines

2

- Product versions, dimensions and loads
- Ergonomic guidelines and work environment requirements
- Handling area dimensions and limitations

Analysis & Concept design

3

- Layout schema for workstation
- Summary of suitable solution alternatives
- Prototypes and special versions if needed

Development & Assessment

4

- For complex handling operations, a conceived product combination can be tested and assessed in the work environment
- Completion and production of the optimal material handling solution

Delivery & Training

5

- Delivery and installation.
- Training with review of the manual, safety features and maintenance recommendations
- Reconciliation of customer satisfaction

Service & Warranty

6

- Warranty period as per agreement
- Standardized spare parts with fast delivery times
- Extensive service organization via partners
- Possibility of flexible and customized service agreement

Product focus vs. customer focus

Contrary to other actors in the lifting industry, we do not start off with a specific product in mind when we try to solve a handling problem.

We always focus on customer needs and optimal handling before selecting products!

¹ The process is described in general and can vary in detail between companies and different types of material handling operations.

LIFTING SOLUTIONS FOR YOUR INDUSTRY

Movomech's ergonomic lifting manipulators and gripper tools for professional material handling streamline production processes and improve the working environment in many industries. Here are some examples of how.

More handling solutions can be found at: www.movomech.com/lifting-equipment



SHEETS AND PANELS

The handling of flat panels, such as glass, metal sheeting, doors, and plastic and wooden boarding, is one of the most common lifting tasks performed in workplaces around the world on a daily basis.



GLASS AND WINDOWS

Movomech's lifting equipment for glass and window handling enables personnel to safely lift, tilt and rotate panes of glass or entire windows while maintaining good ergonomic postures during assembly work. The object is lifted safely and ergonomically using a specially designed gripper and is not damaged in any way.



BOXES AND CARTONS

The lifting of boxes and cartons is a common activity in industry, an activity that can tire personnel and cause aches and pains if carried out for long periods, with a large degree of repetitiveness, in unfavourable positions or with heavy loads.





AUTOMOTIVE PARTS

Manual lifting equipment for the automotive industry is characterized by the industry's high demands on safety, ergonomics, accessibility and quality. Such equipment is often adapted to the production of different model variants on the same production line, which means less conversion time and lower investment costs.



APPLIANCES

In production processes that entail lifting appliances and furniture during assembly or packing, this can be a daunting task as the products are both bulky and heavy.

Appropriate lifting aids are a prerequisite for safe and efficient material handling.



SACKS AND BAGS

Sack lifting is frequently an ergonomic challenge. Not only are sacks often heavy and comprised of hard-to-grasp material, their shape and firmness can vary and the centre of gravity can shift during handling, which increases the physical strain on personnel.



MISCELLANEOUS

Movomech has extensive experience of developing customized lifting units and designing tailor-made support equipment, including stands, roller tables and fixtures. Standard modules and lifting devices from other manufacturers are also offered as a complement to our own lifting equipment.

MOVOMECH® JIB CRANES

Movomech's range of ergonomic jib cranes comprises a complete series of wall and pillar-mounted jib cranes, as well as complete lifting units with integrated lifting devices – balance lifters, chain hoists or vacuum lifters.

Several of the jib cranes can be supplied with a mobile platform, for easy repositioning to different workstations.

MECHCRANE™

Wall-mounted jib cranes LVS AVS
0-250 kg

The crane arm is equipped with a sturdy and extremely easy-rolling aluminium trolley, fitted with high-quality wheel bearings for ergonomic material handling that is both quiet and smooth.

Mechcrane™ wall-mounted jib cranes LVS/AVS are offered in any length of 0.5 m multiples.



MECHCRANE™

Pillar-mounted jib cranes LPS APS
0-250 kg

Movomech's pillar-mounted jib cranes are equipped with rigid pillars in painted steel and jib arms made from strong and light aluminium profiles from the Mechrail™ crane system range.

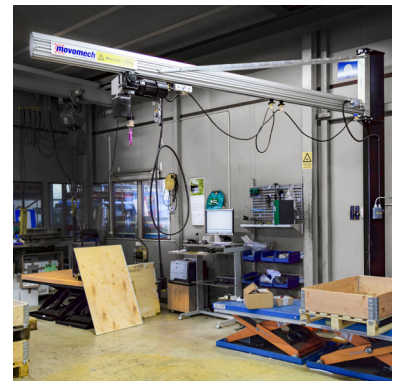

MECHCRANE™

Articulated jib cranes VKA
0-200 kg

Mechcrane™ articulated jib cranes VKA offer you maximum reach in your work area with minimal movement resistance. The two articulated crane arms are rotated via roller bearings of the highest quality for light and ergonomic material handling.





MECHCRANE™

Articulated jib crane with hoist VKA-H
0-125 kg

The Mechcrane™ articulated jib crane VKA-H combines the best of two worlds with an easily operated ergonomic articulated jib crane with a frequency controlled Mechchain Pro II™ chain hoist fully integrated into the outer crane arm.



MOBIARM™

Mobile articulated jib crane
0-125 kg

MobiArm™ is an ergonomic articulated jib crane that can be adapted to each individual workplace, with a reach of up to 4 meters, and a height-adjustable floor pillar. Add a mobile platform and you can easily move MobiArm™ between different workstations – a simple manual pallet truck will suffice!

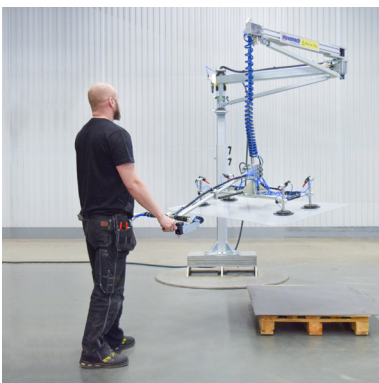

MECHLINE PRO CRANE™

Mobile articulated jib crane with balancer
0-50 kg

Mechline Pro Crane™ – by combining the smoothness of the Mechline Pro™ balance lifter with the versatility of an articulated jib crane, we have created a flexible lifting solution for many different industries.



EASYCRANE™

Mobile articulated jib crane with vacuum lifter
5-55 kg

Easycrane™ is an intuitive and easy-to-use lifting device for quick and easy lifting. Easycrane™ consists of a flexible articulated jib crane with a vacuum lifter integrated in the outer jib arm.

EASYCRANE V™

Mobile articulated jib crane with vacuum lifter
5-80 kg

Easycrane V™ is a powerful vacuum lifter for sacks or porous cartons. With a short handle for easy bag handling or extended handle for increased reach when stacking or handling material.



MOBICHAIN™

Mobile articulated jib crane with frequency
controlled lifting unit, 55-100 kg

Mobichain™ is a unique product that combines the mobile articulated jib crane smoothness with fast, precise and stepless lifting movements via an integrated Mechchain Pro.

MECHRAIL™ CRANE SYSTEM

Mechrail™ is a professional aluminium crane system that improves the working environment at world-leading automotive manufacturers, as well as at mechanical workshops and industrial companies in most sectors.

The aluminium profiles in the Mechrail™ system have been designed for maximum strength and torsional rigidity combined with a very low tare weight, making Mechrail™ a very easy-to-use and ergonomic crane system. The starting force and the rolling resistance experienced by the operator during handling are among the absolute lowest on the market.

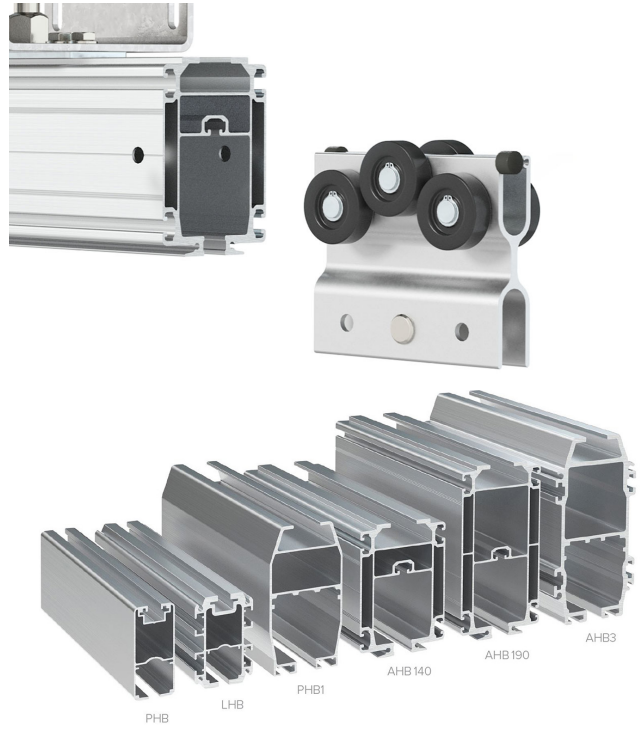

Design for optimal ergonomics and extreme longevity

The trolleys in the Mechrail™ range have a high strength aluminium frame and are equipped with extremely easy-rolling plastic wheels with premium quality bearings.

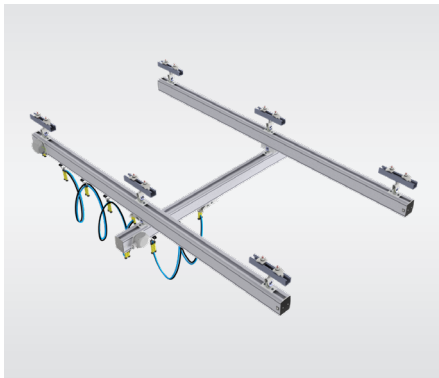

Single crane

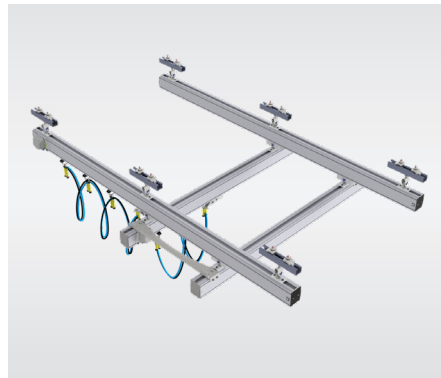

Double crane

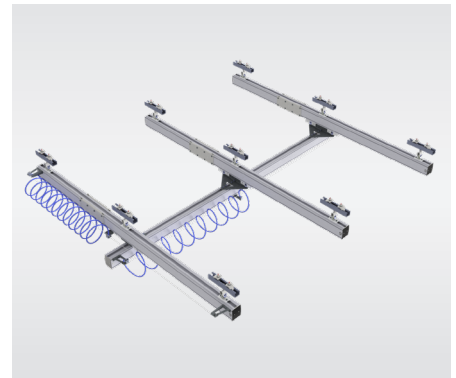

Tripple track

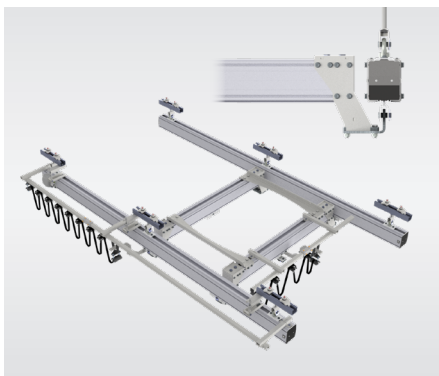

Space saving modules for low ceilings

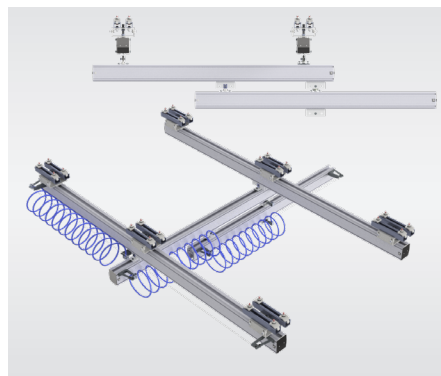

Telescopic cranes maximise the reach



External electrical power rails for flexibility

MOVOMECH® MECHCHAIN PRO™

Electric chain hoists are smooth-operating lifting devices suitable for many industries.

Back in 1995, Movomech was among the first companies to develop a frequency-controlled chain hoist for professional lifting, the Mechchain™. This type of chain hoist performs best in handling with strict demands on ergonomics, feel and precision.



MECHCHAIN PRO II™

High-precision hoist
0-225 kg

A high-precision hoist whose main strength is the combination of good control and high precision. In addition to this, the lifter has an impressive lifting speed of up to 16 m/min. Frequency control provides a continuously variable lifting speed controlled by the joystick.



For high availability even in challenging environments, Mechchain Pro II™ has been equipped with a control unit in aluminium with a quick connector for the control cable.

A selection of optional standard control unit brackets are also available for easy installation on gripper tools or vacuum yokes.

MOVOMECH® INDUSTRIAL MANIPULATORS

Movomech has developed and manufactured lifting manipulators under its own brands and in its own production facilities in Kristianstad for over 30 years.

All lifting manipulators are inspected before delivery with thorough quality checks and tests to ensure that the final product complies with current regulations and is of a high standard.

MECHLIFT PRO E™

Electric industrial manipulator
0-650 kg | 0-1500 Nm

Mechlift Pro E™ is an extremely versatile moment absorbing lifting unit that is easily adapted to many types of handling solutions. It can be fitted with standard or custom gripper tools, as well as with accessories such as rotation units, brake units, and programmable stop positions.

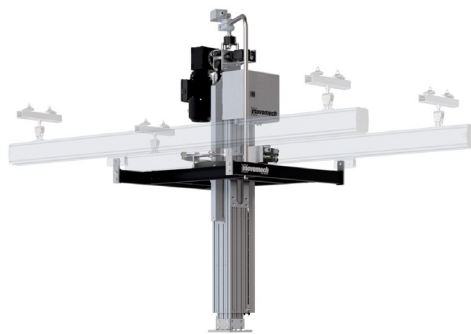

MECHSTICK™

Electric industrial manipulator
0-100 kg | 0-700 Nm

Light and flexible lifting manipulator that offers a stroke of up to 4 meters and is controlled just like other electrically powered Movomech manipulators with joystick via frequency converter. This means smooth, stepless lifting movements that combine speed with high precision.



MECHSTACK PRO™

Electric stapler
0-650 kg | 0-4000 Nm

As standard, this industrial manipulator has a working stroke length of up to almost 5 metres. It is controlled and steered with a joystick via a frequency converter, providing a continuously variable and synchronous lifting speed. The simplex driving chains, connecting the drive axle with the trolleys, are well-protected inside the aluminium profiles.





MECHLINE PRO™

Pneumatic wire balancer
0-50 kg

Mechline Pro™ is an intuitive and easy-to-operate pneumatic wire balancer for light loads of up to 50 kg. The lifting wire is extremely durable and can be used for up to 300,000 work cycles.

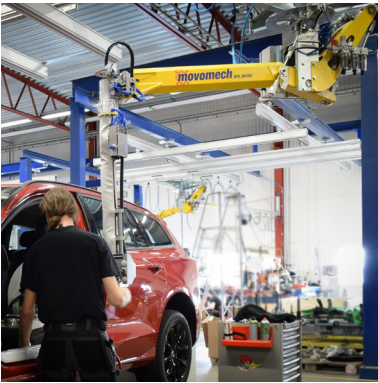

MECHSPACE PRO™

Pneumatic industrial manipulator
0-150 kg | 0-1500 Nm

Mechspace Pro™ is available in two versions: suspended or pillar-mounted. Its moment-absorbing capacity offers great advantages when handling items with complex geometries, as well as for gripping and rotating of eccentric loads.

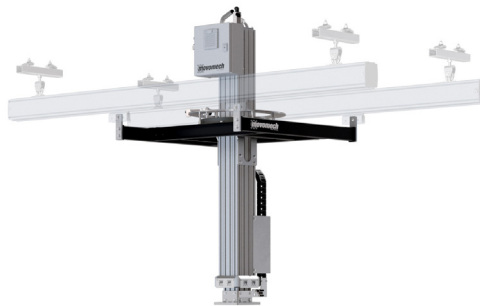

MECHLIFT PRO P™

Pneumatic industrial manipulator
0-150 kg | 0-1000 Nm

Pneumatic Mechlift Pro P™ is a versatile pneumatic moment-absorbing industrial manipulator suitable for many types of lifting for loads of up to 150 kg. A pneumatic gripping tool and control units are easily integrated with the tool adapter.

**MOVOMECH®
VACUUM LIFTERS**

Movomech vacuum lifters streamline material handling and allow you to lift and move loads efficiently, gently and ergonomically.

With the right lifting device, different materials such as wood, glass, stone, metal, cardboard, paper and plastic can be lifted safely and gently with a vacuum without leaving marks on the surface.





VACUHAND PRO™

Vacuum lifter
5-250 kg

Vacuhand Pro™ is manoeuvred with a handle for two-handed operation and enables the easy and efficient handling of sacks, cardboard boxes and sheet material.

When it comes to handling sacks, Vacuhand Pro™ is a given choice thanks to the lifter's high capacity and great adaptability.



EASYHAND M™

Vacuum lifter
5-55 kg

Easyhand M™ is a flexible vacuum lifter with a modular design for loads of up to 55 kg. It brings ease and convenience to the handling of everything from sacks and cardboard boxes to sheet materials such as glass, sheet metal and doors.



EASYHAND PRO™

Vacuum lifter
5-55 kg

The lifting and lowering function is regulated with an ergonomically designed control handle. Controls on the operating handle make it easy to adjust the lifter's stand-by height with or without a load.



EASYHAND PRO RAPID™

Vacuum lifter
5-35 kg

Easyhand Pro Rapid™ is a very fast one-handed handling. Equally user-friendly for both right- and left-handed operators. Easyhand pro Rapid is equipped with a "quick release" function designed for fast and efficient carton and luggage handling.

MOVOMECH® GRIPPER TOOLS

Movomech has over 30 years of experience of developing and manufacturing premium-quality ergonomic gripper tools for most industries.

Productivity, ergonomics and safety are always our core focus and we strive to find the optimal handling solution for each need.



GLASS HANDLING AGR

Standard gripper tools

In addition to reducing the risk of occupational injuries and sick leave, AGR equipment increases efficiency and flexibility at the workplace in that windscreen replacement becomes a job for one rather than two fitters.

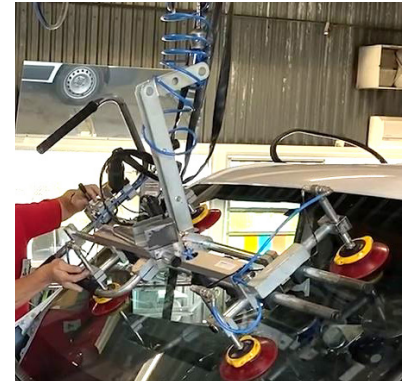
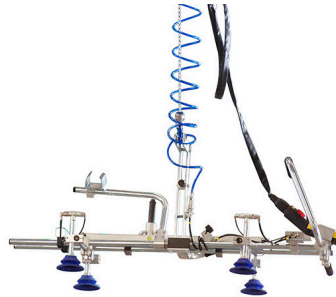

PANEL GRIPPER TOOL

Standard gripper tools

Movomech's modular panel lifting tool facilitates the lifting of panels, cartons and board material in many different trades and industries. The panel handling tool concept has a generous number of accessories and configuration options – making it perfectly adapted to each unique workstation.

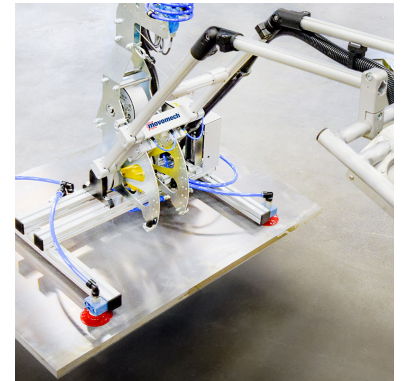

VACUUM GRIPPER TOOLS

Bespoke gripper tools

Suction cups and vacuum yokes are convenient handling solutions for gripping and lifting many different types of objects. Without leaving marks on the surface, the object is lifted using one or more suction cups and can then be turned and rotated as desired.

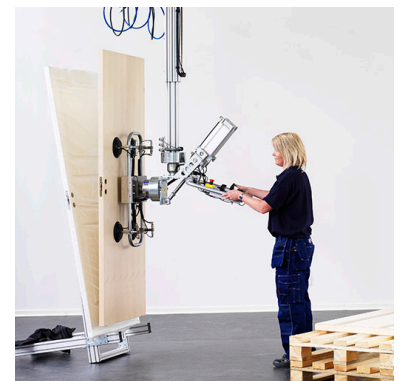



ROLL HANDLING GRIPPER TOOLS

Standard gripper tools

Fully mechanical gripper tools that do not require electricity, pneumatics or hydraulics.

All roller tools have an auto-locking function – the heavier the load, the stronger the gripping teeth lock the roll, which provides safe and secure handling!

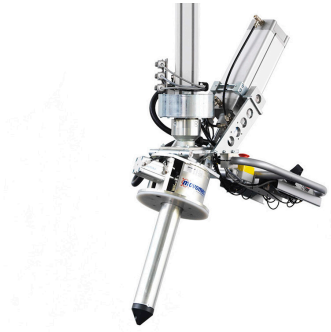

PNEUMATIC GRIPPER TOOLS

Bespoke gripper tools

Pneumatic gripper tools are a safe, economical and flexible solution for gripping and lifting many different types of objects.

The items being handled can include everything from vehicle components and mechanical parts to rollers, drawers, furniture, food packaging and more.



SACK HANDLING TOOL

Customized tool

The perfect tool if you are in need to lift, cut and/or empty sacks of their contents.

The smooth stepless movements and high-precision positioning make sure that the sack stays in position while being cut and emptied.



MAGNETIC GRIPPER TOOLS

Bespoke gripper tools

Magnetic gripper tools are often the ideal solution when handling ferromagnetic workpieces in confined spaces. With magnetic gripping tools, workpieces in different designs can be handled without the tool's contact surfaces having to be precisely matched to the contours of the workpiece.

WORLD-CLASS LIFTING SOLUTIONS

Movomech products and systems are used in many industries and in many countries. Here is a sample of customers who have chosen the Movomech companies as partners in order to improve the efficiency of their production processes.



AUTOMOTIVE

Audi | Autoliv | BMW | DAF | DaimlerChrysler | Faurecia | Ford | General Motors | Jaguar | Johnson Controls | Lear Corporation | MAN | Mercedes Benz | Nissan | Renault | Opel | Peugeot | Porsche | Scania | Tower Automotive | Volkswagen | Volvo AB | Volvo Cars

LINE BUILDERS

ABB | Comau | Dürr | KUKA | Lear Corporation | Magna | ThyssenKrupp | TMS | VDL Steelweld

GENERAL INDUSTRY

ABB | Airbus | Alfa Laval | Anva Industries | Arla | Arvin Meritor | Atlas Copco Tools | Astra Zeneca | Ballingslöv | Cardo | Carglass | Carlsberg Sverige | Daloc | Danfoss | Dooria | DynaMate | Dynapac | Electrolux | European Furniture Group | Finja | Geberit | GPI Systems | Husqvarna | IFO | Jeldwen | Kilsgaard | Kinnarps | Orresta dörr | Outokumpu | Pilkington | Randek BauTech | Saab AB | Schenk | SKF | Statoil | Swedese | Tarkett | TESA | TMHMS | Westinghouse



Movomech AB +46 (0)44 28 29 00

www.movomech.com