

MECHSTACK PRO™

Electric moment-absorbing industrial lifting manipulator

Mechstack Pro™ is an electric industrial lifting manipulator for handling and stacking of loads up to 650 kg and with a moment up to 4000 Nm.

It is controlled and steered with a joystick via a frequency converter, which enables a smooth and ergonomic lifting operation – a great advantage for the operators of stacking or assembly work.



MECHSTACK PRO gives you:

- Ergonomic handling of loads up to 650 kg
- Impressive moment absorption capacity for handling of bulky objects
- Option for integrated air feed to pneumatic gripper tools – even with 360° free rotation
- An aluminium structure with details in galvanized steel, for a lower tare weight and a maintenance-free surface

COMMON APPLICATIONS:

- Mounting of various components into truck cabs at assembly lines
- Assembly stations for doors, chassis, etc
- Stacking of heavy or bulky objects, e.g. pallets, rolls, panels

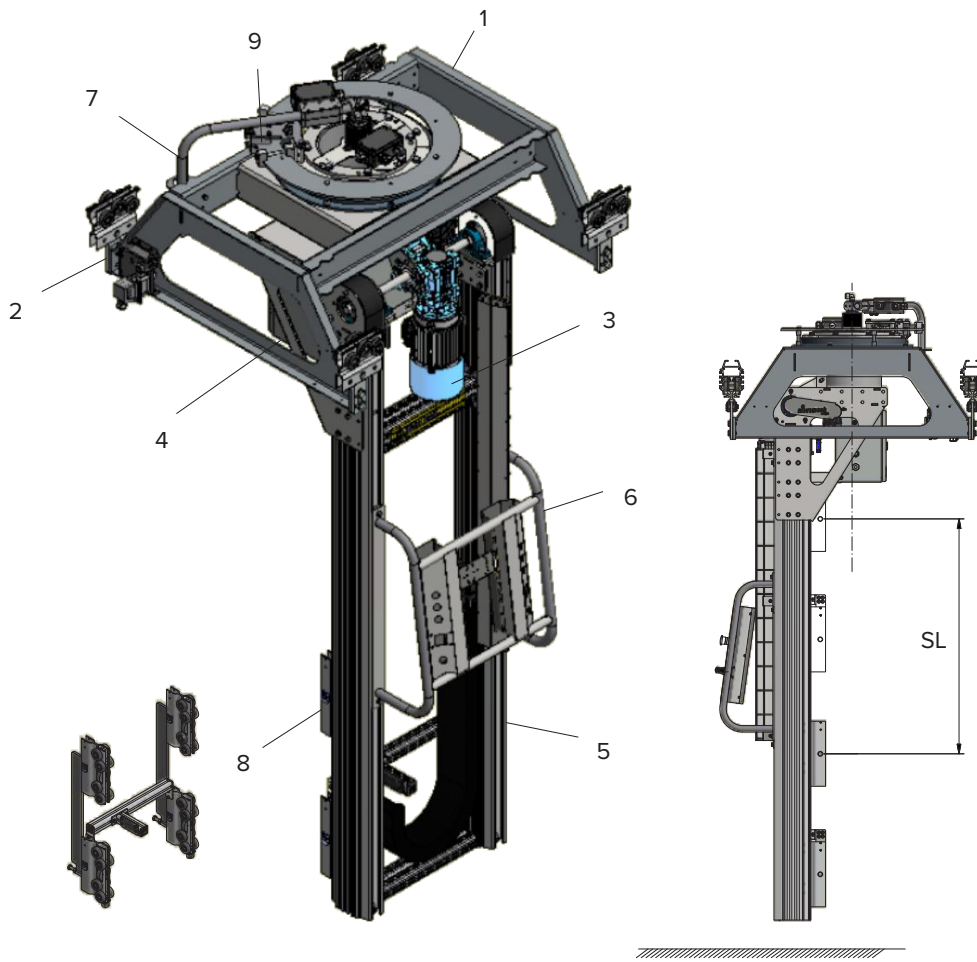

General data		Standard	Heavy Duty
Max. load	[kg]	150 / 250	150 / 250 / 400 / 650
Max. moment	[Nm]	1000 - 2000	1000 - 4000
Max. lifting stroke	[mm]	4910	4835
Lifting speed	[m/min]	0 - 10	0 - 10

- 1. Cross unit
- 2. Suspensions
- 3. Engine unit
- 4. Electric cabinet
- 5. Pillar unit
- 6. Operator handle
- 7. Media connection
- 8. Tool carrier frame
- 9. Rotation brake (option)



LIFTING WITH MECHSTACK PRO

Mechstack Pro has a working stroke length of up to 4 meter. It is controlled and steered with a joystick via a frequency converter which gives a stepless, variable and synchronous lifting speed.

The simplex driving chains, connecting the driving axle with the trolleys, are well-protected in the aluminium profiles. The Heavy Duty version of Mechstack Pro has linear rail guiding for an increased moment-absorbing capacity.

As an option, Mechstack Pro may be equipped with an encoder that reads the shaft in the spindle limit switch. This makes it possible to set a lower stop position, as well as a further two stop/start positions along the stroke length. The positions are stored in a built-in memory in the frequency converter and are not erased in case of power cuts.

A tool frame is available as standard accessory, on which a mechanical, electrical or pneumatic gripper tool can be mounted to provide a unique customized handling solution.